

# OKUMURA ENGINEERING CORPORATION

Our management concept  
(OKUMURA mind)

We will challenge ourselves to expand the '輪:circle' of good work in people and society, with the latest technology and an open heart, aiming to create a prosperous environment.

## 1. Business Profile

Our three main businesses as

### 1. Civil Engineering by Environment Development Department

Mainly constructs tunnels, bridge piers, and pavements, as well as building construction work such as condominiums and office buildings.

### 2. Lifeline Construction by LG(Life&Gas) Department

Carries out gas piping work and road pavement work associated with it.

### 3. Construction Material by Product Department

Manufactures and sells aggregates such as macadam, gravel, sand, etc., and recycles asphalt mixtures and concrete blocks

**NICE WORK,  
NICE COMMUNICATION.**

- Civil Engineering
- Lifeline Construction
- Construction Material



Company Overview movie(JPN)

## 2. Company Profile

Company name	OKUMURA ENGINEERING CORP.
Address	11-18 Misaki Minato-ku Osaka
Founded	January 1920
Capital	JPY 1,000 Mln
Sales amount	JPY 53,100 Mln
Employee	892 (as July 2023)



We, Okumura Engineering are located in Osaka City in the Kansai region of Japan, nearby Universal Studios Japan.

## 3. Our result(Civil Engineering)

Site : Shin-MeiShin Expressway Kawanishi IC

Contract amount : JPY 14,175 Mln Construction period : 5.8 years

Outline : Earthwork for bridge substructures and interchange



Site : Arakawa river 2nd regulating reservoir foundation 1st work

Contract amount : JPY 851 Mln Construction period : 11 months

Outline : Foundation work for Arakawa river right bank : L=1,780m



# OKUMURA ENGINEERING CORPORATION

Our management concept  
(OKUMURA mind)

We will challenge ourselves to expand the '輪:circle' of good work in people and society, with the latest technology and an open heart, aiming to create a prosperous environment.

## 4. Our result(Paving work)

Site : Shin-MeiShin Expressway JoyoYawatai  
 Contract amount : JPY 3,606 Mln Construction period : 1.9 years  
 Outline : Paving work for new construction : L=5,220m



Construction status of high-performance pavement

## 5. Introduction of Product Department

Our company's original business that manufactures and sells construction materials

### Stable supply of materials



Company carrier 'TOKOWAKA'

This type of carrier is specialized to carry macadams, gravel and sand, equips grab crane for lading and unloading them.



Asphalt mixing plant

## 6. Introduction of R&D

### Rock cutting method with Surface miner technology

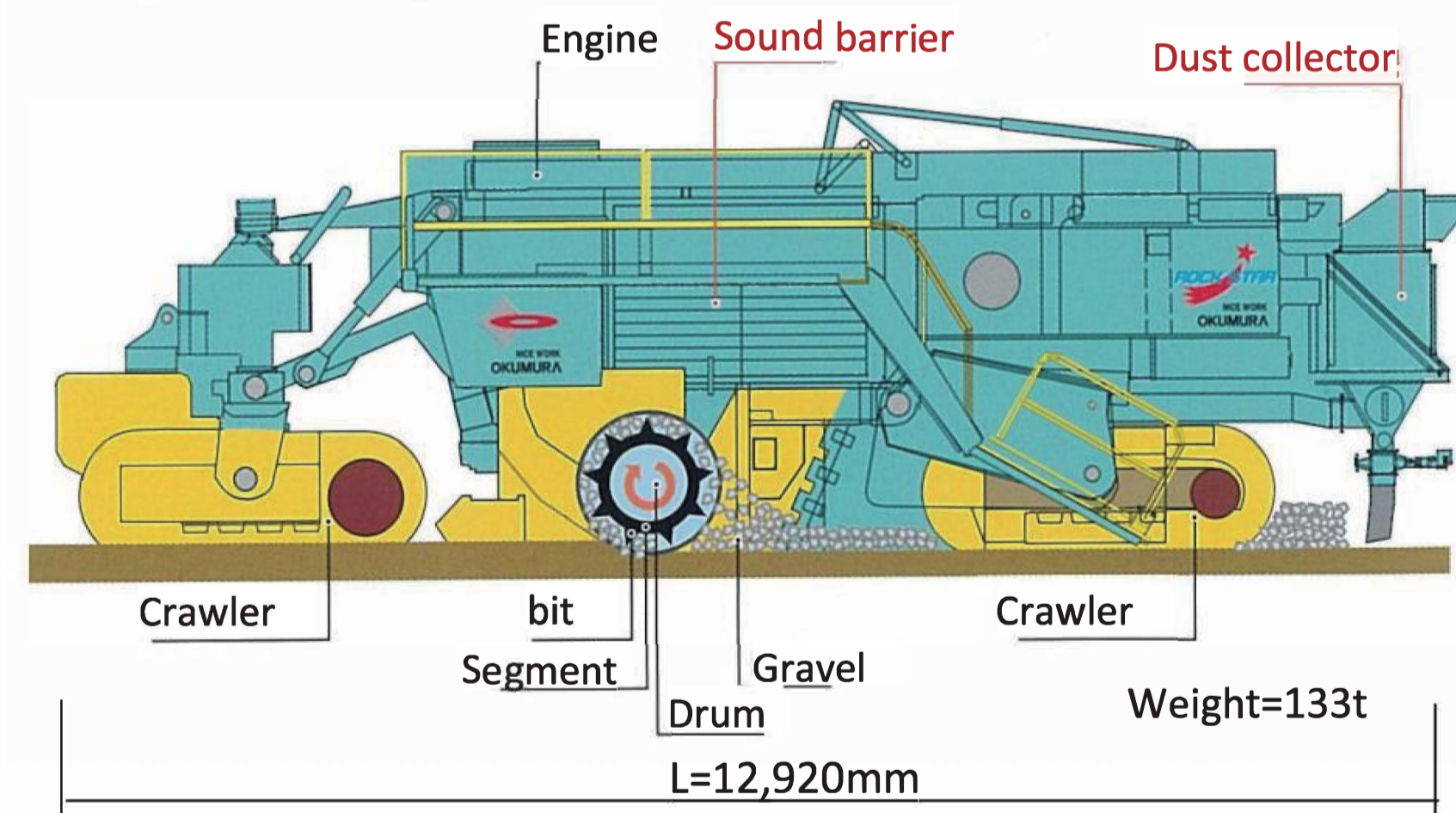

### What surface miner?

Can efficiently and accurately carry out excavation work on bedrock with low noise and low vibration, collaborative development with Wirtgen, Germany. Suits for sites prohibited to apply blasting method.

### Long-distance & sharp curved pipe jacking method (COSMIC method)

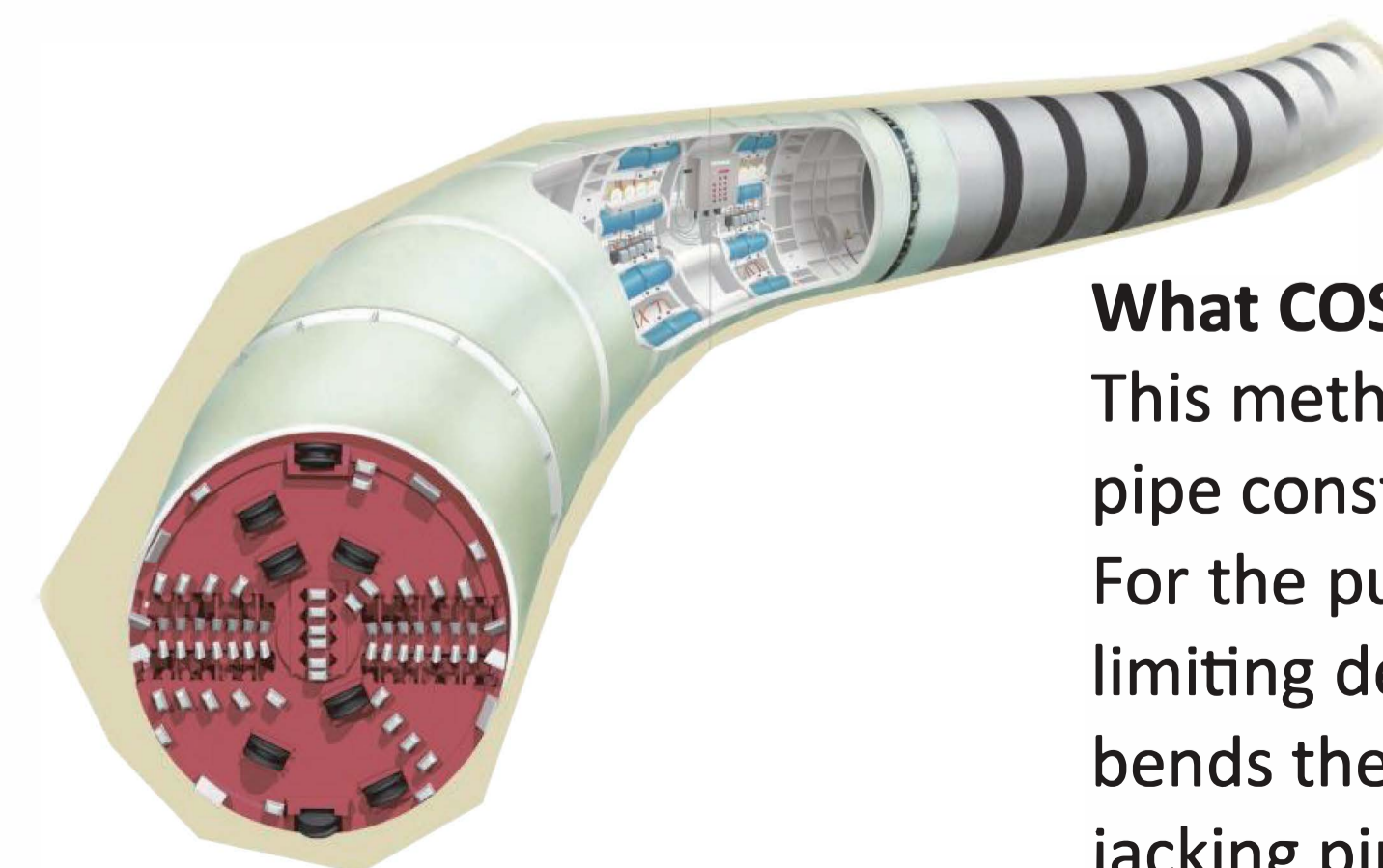

### What COSMIC method?

This method enables long-distance sharp curves pipe construction economically. For the purpose we developed a low-thrust friction limiting device, a sharp curve forming device that bends the curve as designed, and a high-strength jacking pipe.